

Eurocell Profiles Ltd

Fairbrook House
Clover Nook Road
Alfreton
Derbyshire DE55 4RF
Tel: 01773 842100 Fax: 01773 842199
e-mail: info@eurocell.co.uk
website: www.eurocell.co.uk



Agrément Certificate
01/3783
Product Sheet 1

EUROCELL ROOFLINE SYSTEMS

EUROCELL PVC-U ROOFLINE SYSTEM

This Agrément Certificate Product Sheet⁽¹⁾ relates to the Eurocell PVC-U Roofline System, comprising white PVC-U fascia, soffit and barge boards, soffit ventilator and accessories, for external use at the roofline as a substitute for timber or other conventional materials.

(1) Hereinafter referred to as 'Certificate'.

CERTIFICATION INCLUDES:

- factors relating to compliance with Building Regulations where applicable
- factors relating to additional non-regulatory information where applicable
- independently verified technical specification
- assessment criteria and technical investigations
- design considerations
- installation guidance
- regular surveillance of production
- formal three-yearly review.

KEY FACTORS ASSESSED

Resistance to moisture — the system will provide satisfactory protection against moisture ingress to the interior of the building (see section 6).

Ventilation — the ventilated soffit board can contribute towards providing the necessary roof space ventilation (see section 7).

Strength and stability — in terms of wind loading resistance, the system can be used in all areas of the UK (see section 8).

Performance in relation to fire — the cellular boards achieve a Class 1/Class 1Y surface spread of flame classification when tested in accordance with BS 476-7 : 1997 and BS EN 13245-2 : 2008 (see section 9).

Durability — the system will retain its impact resistance and decorative qualities for a period in excess of 35 years with only minor changes in surface appearance (see section 11).



The BBA has awarded this Certificate to the company named above for the system described herein. This system has been assessed by the BBA as being fit for its intended use provided it is installed, used and maintained as set out in this Certificate.

On behalf of the British Board of Agrément

John Albon — Head of Approvals
Construction Products

Claire Curtis-Thomas
Chief Executive

Date of Second issue: 8 March 2019

Originally certificated on 18 January 2001

Certificate amended on 6 August 2019 to include Regulation 7(2) for England and associated text.

The BBA is a UKAS accredited certification body – Number 113.

The schedule of the current scope of accreditation for product certification is available in pdf format via the UKAS link on the BBA website at www.bbacerts.co.uk

Readers are advised to check the validity and latest issue number of this Agrément Certificate by either referring to the BBA website or contacting the BBA direct.

Any photographs are for illustrative purposes only, do not constitute advice and should not be relied upon.

British Board of Agrément

Bucknalls Lane
Watford
Herts WD25 9BA

©2019

tel: 01923 665300
clientservices@bbacerts.co.uk
www.bbacerts.co.uk

Regulations

In the opinion of the BBA, the Eurocell PVC-U Roofline System, if installed, used and maintained in accordance with this Certificate, can satisfy or contribute to satisfying the relevant requirements of the following Building Regulations (the presence of a UK map indicates that the subject is related to the Building Regulations in the region or regions of the UK depicted):



The Building Regulations 2010 (England and Wales) (as amended)

Requirement:	C2(b)	Resistance to moisture
Comment:		The system will contribute to providing protection against the penetration of moisture to the inner surface of the building on which it is installed. See section 6 of this Certificate.
Requirement:	C2(c)	Resistance to moisture
Comment:		When used in accordance with this Certificate, the system can contribute to enabling a roof to satisfy this Requirement. See section 7 of this Certificate.
Regulation:	7	Materials and workmanship (applicable to Wales only)
Regulation:	7(1)	Materials and workmanship (applicable to England only)
Comment:		The system is acceptable. See section 11.1 and the <i>Installation</i> part of this Certificate.
Regulation:	7(2)	Materials and workmanship (applicable to England only)
Comment:		The system may be restricted in some cases by this Regulation. See section 9.1 of this Certificate.



The Building (Scotland) Regulations 2004 (as amended)

Regulation:	8(1)(2)	Durability, workmanship and fitness of materials
Comment:		The system is acceptable. See sections 10.1 and 11.1 and the <i>Installation</i> part of this Certificate.
Regulation:	9	Building standards applicable to construction
Standard:	3.10	Precipitation
Comment:		The system will contribute to satisfying this Standard with reference to clause 3.10.1 ⁽¹⁾⁽²⁾ by giving protection against the penetration of moisture to the inner surface of the building on which it is installed. See section 6 of this Certificate.
Standard:	3.15	Condensation
Comment:		The system can contribute to enabling a roof to satisfy this Standard, with reference to clauses 3.15.1 ⁽¹⁾ , 3.15.3 ⁽¹⁾ , 3.15.5 ⁽¹⁾ and 3.15.7 ⁽¹⁾ . See section 7 of this Certificate.
Regulation:	12	Building standards applicable to conversions
Comment:		All comments given for these systems under Regulation 9, Standards 1 to 6, also apply to this Regulation, with reference to clause 0.12.1 ⁽¹⁾⁽²⁾ and Schedule 6 ⁽¹⁾⁽²⁾ . (1) Technical Handbook (Domestic). (2) Technical Handbook (Non-Domestic).



The Building Regulations (Northern Ireland) 2012 (as amended)

Regulation:	23	Fitness of materials and workmanship
Comment:		The system is acceptable. See section 11.1 and the <i>Installation</i> part of this Certificate.
Regulation:	28	Resistance to ground moisture and weather
Comment:		The system will contribute to providing protection against the penetration of moisture to the inner surface of the building on which it is installed. See section 6 of this Certificate.
Regulation:	29	Condensation
Comment:		The system can contribute towards enabling a roof to satisfy the requirements of this Regulation. See section 7 of this Certificate.

Construction (Design and Management) Regulations 2015

Construction (Design and Management) Regulations (Northern Ireland) 2016

Information in this Certificate may assist the client, designer (including Principal Designer) and contractor (including Principal Contractor) to address their obligations under these Regulations.

See sections: 3 *Delivery and site handling* (3.2) and 13 *General* (13.6 to 13.8) of this Certificate.

Additional Information

NHBC Standards 2019

In the opinion of the BBA, Eurocell PVC-U Roofline System, if installed, used and maintained in accordance with this Certificate, can satisfy or contribute to satisfying the relevant requirements in relation to *NHBC Standards*, Chapter 7.2 *Pitched roofs*.

Technical Specification

1 Description

1.1 The Eurocell PVC-U Roofline System is for external use on roofs as a substitute for timber or other conventional materials.

1.2 The system comprises a range of white PVC-U (PVC-UE) boards including fascia/barge boards (see Figure 1) and plain and vented soffits (see Figure 2), together with ancillary components including extruded trims and injection-moulded joints (see Figure 3)

Figure 1 Cellular boards

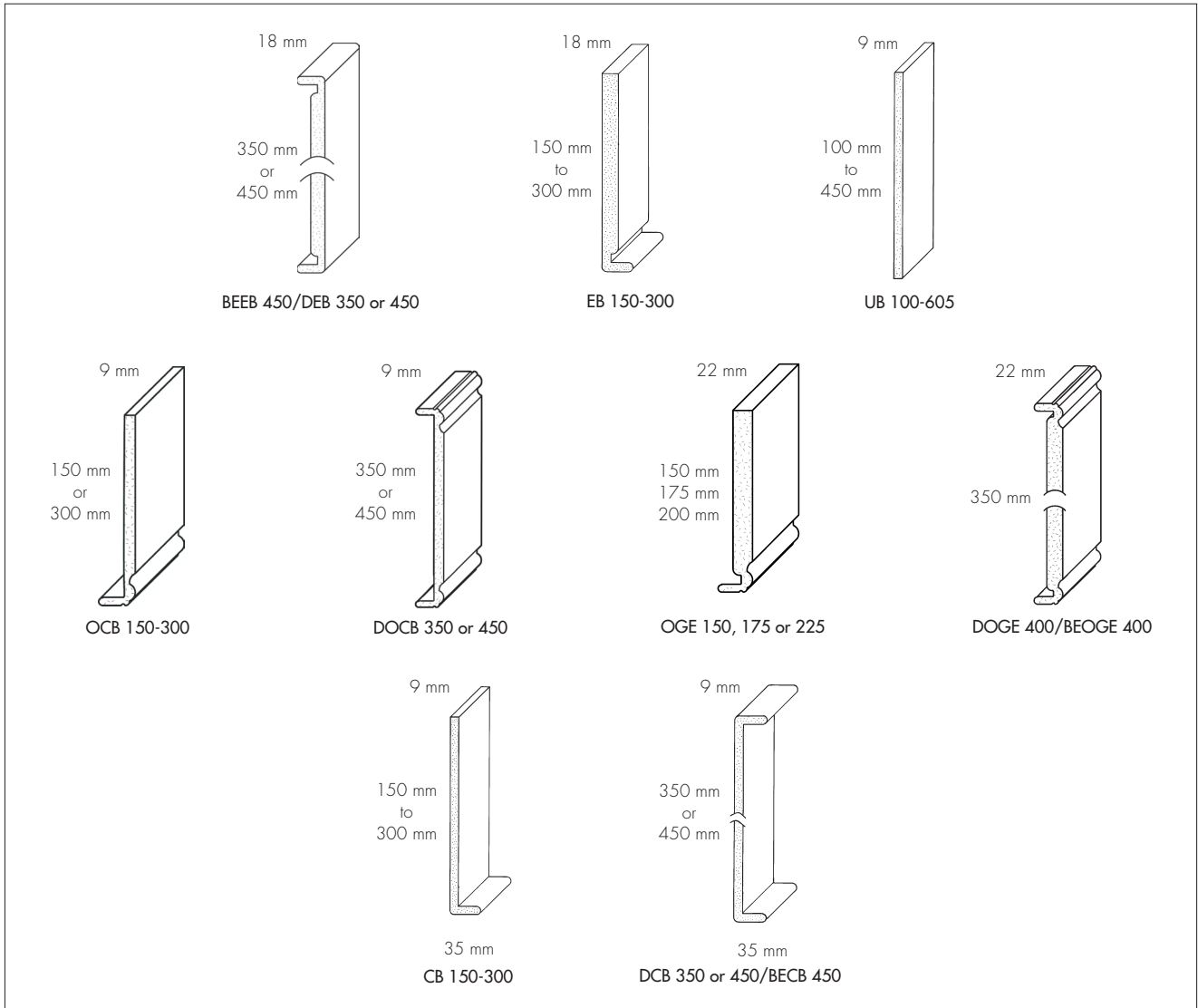

Figure 2 Soffit boards

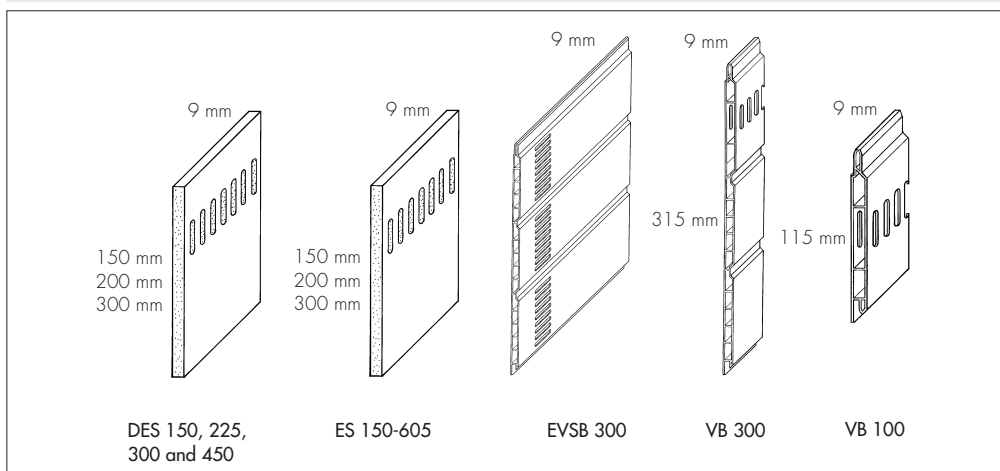
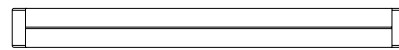
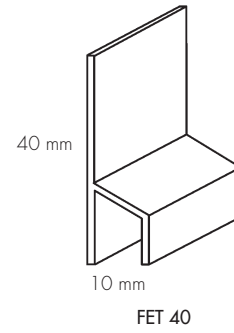
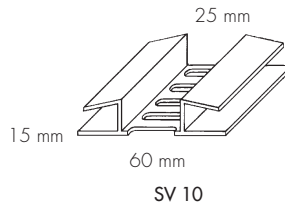
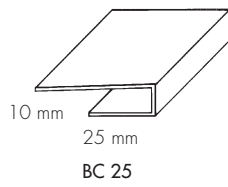
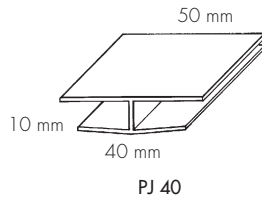
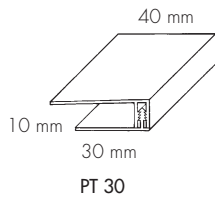
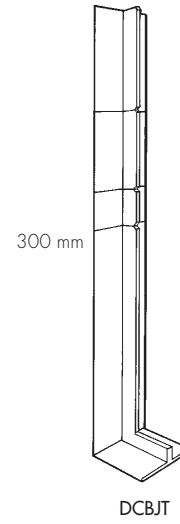
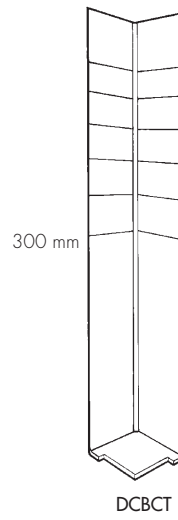
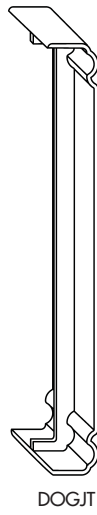
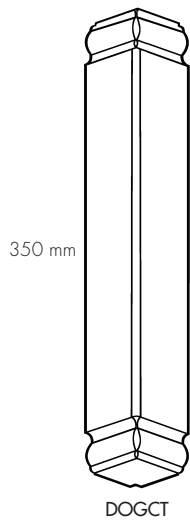
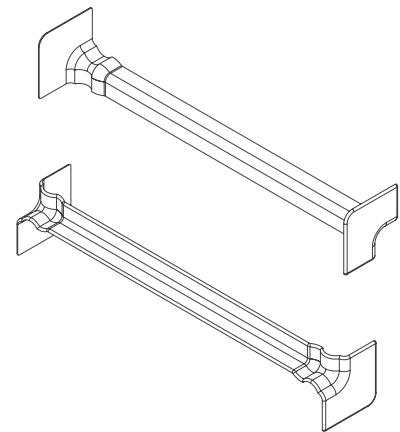
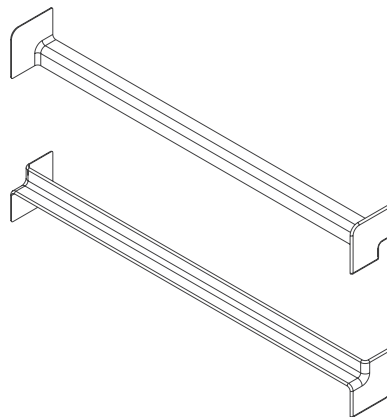
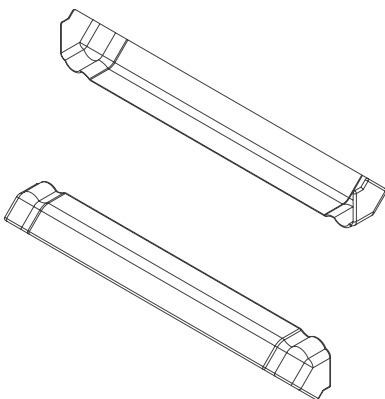

Figure 3 Selection of typical components and trims



BNJT



1.3 The soffit ventilator products, which include vented cellular boards, vented hollow boards and a ventilator trim, provide a means of ventilating the roof void.

1.4 The cellular boards comprise a closed cell PVC-UE core, beneath an outer weathering impact-modified PVC-U skin. The extruded trims are composed of impact-modified PVC-U and the injection mouldings of PVC-U.

1.5 The fascia/barge boards are available in thicknesses of 9 mm, 18 mm and 22 mm, in a range of widths from 100 mm to 450 mm, in standard 5 m lengths of average density $0.55 \text{ kg}\cdot\text{m}^{-3}$ and with a nominal skin thickness of 0.5 mm.

1.6 The recommended fixings for use with various components of this system are listed in Table 1.

Table 1 System components and their recommended fixings

Component thickness	Type of fixing
9 mm capping board and timber backing board	50 mm long (FN50) nails
18 mm Euroboard and 22 mm Ogee board	65 mm long (FN65) nails
9 mm utility board, Euro soffit board and rigid hollow soffit board	30 mm long (FP30) pins
9 mm capping board	Stainless steel 50 mm long capping screws (CS50), with a plastic cover
100 mm rigid hollow soffit panel	Stainless steel 25 mm long cladding pins (CP25)

1.7 A PVC solvent adhesive is used to secure joint and corner trims. The Certificate holder can recommend suitable materials for this purpose, but their performance is outside the scope of this Certificate.

2 Manufacture

2.1 The boards are manufactured by co-extruding a high-impact calcium/zinc PVC-U compound onto a foamable calcium/zinc PVC-UE core compound, and cooling and forming to section. Cellular PVC-UE is formed during the process by the evolution of gas from sodium bicarbonate present in the foamable PVC-U compound. A clear protective polyethylene film is applied to the outer face of the extrusion before the board is cut to length.

2.2 The ancillary components are manufactured using conventional extrusion and injection-moulding techniques.

2.3 As part of the assessment and ongoing surveillance of product quality, the BBA has:

- agreed with the manufacturer the quality control procedures and product testing to be undertaken
- assessed and agreed the quality control operated over batches of incoming materials
- monitored the production process and verified that it is in accordance with the documented process
- evaluated the process for management of nonconformities
- checked that equipment has been properly tested and calibrated
- undertaken to carry out the above measures on a regular basis through a surveillance process, to verify that the specifications and quality control operated by the manufacturer are being maintained.

2.4 The management system of Eurocell Profiles Ltd has been assessed and registered as meeting the requirements of BS EN ISO 9001 : 2015 (Certificate FM 45551) and BS EN ISO 14001 : 2015 (Certificate 25110/A/0001/UK/En) by BSI.

3 Delivery and site handling

3.1 The cellular boards and trim profiles are delivered to site in packs sealed in polythene sleeves bearing the Certificate holder's marking. Pack quantities vary, depending on the type of profile.

3.2 Packs should be unloaded by hand to avoid damage, and stored on a clean, level surface in stacks not exceeding one metre in height and restrained from collapse. If stored externally, the packs should be kept under cover away from direct sunlight.

3.3 Care must be taken when handling PVC-U boards and trims to avoid contact with solvents or materials containing volatile organic components.

Assessment and Technical Investigations

The following is a summary of the assessment and technical investigations carried out on the Eurocell PVC-U Roofline System.

Design Considerations

4 General

4.1 The Eurocell PVC-U Roofline System is suitable for use externally to provide a protective and decorative trim at the roofline where timber or other conventional materials would normally be used.

4.2 The system must be fixed only to structurally sound building substrates, at centres not exceeding 600 mm. Rafter feet and gable ladders should be adequately supported by noggings to ensure rigidity. Replacement, rather than over fixing, of existing fascia is recommended. Timber roof structures to which the system is fixed must be designed and/or constructed in accordance with the relevant national Building Regulations and BS EN 1995-1-1 : 2004 and its National Annex.

4.3 The cellular PVC-UE components have a similar coefficient of thermal expansion to that of conventional solid PVC-U. A 5 mm gap should be provided at the end of each board, (ie 10 mm at the joint trim between boards), to allow for movement.

4.4 The system should not be installed in extremes of temperature. The recommended temperature for installation is between 5°C and 25°C.

4.5 Where the timber structure is preservative-treated with copper, chrome or boron, care must be taken to ensure that sufficient time is allowed for complete fixation of the preservative (approximately seven days) to avoid corrosion of screws and nails used to fix the components.

5 Practicability of installation

The system can be installed by a competent general builder, or a contractor, experienced with this type of system.

6 Resistance to moisture



The system will provide satisfactory protection to prevent moisture ingress to the interior of the building.

7 Ventilation



7.1 Ventilation products can contribute towards providing the necessary roof space ventilation. Guidance on the provision of adequate ventilation is given in the documents supporting the national Building Regulations and BS 5250 : 2011, Clause H.

7.2 When providing roof space ventilation, it is essential that the airway does not become blocked by the loft insulation. This may be achieved by the use of an insulation retainer which produces an air passage with a geometric free area at least equal to that of the soffit ventilator used.

7.3 The vented area and equivalent continuous vent width at eaves for the ventilation products are given in Table 2.

Table 2 Vented boards and trims

Product	Vented area (mm ² .m ⁻¹)	Equivalent continuous vent width (mm)
Vented cellular soffit board	11 500	11.5
Vented hollow soffit board	10 200	10.2
Soffit ventilator trim	12 100	12.1

7.4 The soffit ventilators referred to in Table 2 will meet the ventilation requirements for the application detailed in section 7.5 and contribute to meeting the requirements for applications described in sections 7.6 and 7.7.

7.5 For roofs with a pitch of 15° or more, where both the ceiling and insulation are horizontal, soffit ventilators with a minimum effective area of 10 000 mm² per metre run, if used in accordance with section 7.2, can provide adequate ventilation to insulated loft spaces as set out in BS 5250 : 2011, Clause H. The soffit ventilation products should run along the eaves of the longest opposite sides of a rectangular roof, to provide adequate cross-ventilation. The ventilators are suitable for use with traditional (semi-permeable) and high-performance (impermeable) sarking felts. Consideration should be given to the use of high-level ventilation openings to increase the ventilation rate for roofs, as recommended in BS 5250 : 2011, Clause H. The use of high-level ventilation openings is strongly recommended in roofs with a pitch greater than 35° or roof spans in excess of 10 m.

7.6 For roofs where the ceiling follows the pitch of the roof, soffit ventilation products with a minimum vented area of 25 000 mm² per metre run, if used in conjunction with suitable high-level ventilation, can provide adequately for roof voids as set out in BS 5250 : 2011, Clause H. It is essential that a minimum unrestricted air space of 50 mm is maintained between the underside of the roof deck and the top of the insulation. Consideration should be given to the probability of the sarking felt bowing between rafters and it should be ensured that this does not reduce the gap between felt and insulation to less than 50 mm. Where there is an obstruction to the ventilation, eg rooflights or a change in pitch of roof, adequate ventilation in accordance with the requirements of BS 5250 : 2011, Clause H, should be provided above and below the obstruction using suitable ventilators.

7.7 For roofs with a pitch less than 15°, soffit ventilation products with a minimum vented area of 25 000 mm² per metre run, if used in accordance with section 7.2, can provide adequate ventilation to insulated roof voids, as set out in BS 5250 : 2011, Clause H. When providing roof space ventilation for flat roofs, it is essential that a minimum unrestricted air space of 70 mm is maintained between the underside of the roof deck and the top of the insulation. Ventilation should be provided along two opposite sides of the deck: where possible these should be the two longest sides, to achieve maximum cross-ventilation. The recommendations contained in BS 5250 : 2011, Clause H, should

be followed when planning the provision of ventilation for flat roofs (especially where spans exceed 7 m) or concrete deck roofs. Where a flat roof has a span greater than 10 metres, or is not of a simple rectangular plan, more ventilation will be required, totalling at least 0.6% of the total area of the roof. It should be noted that cold flat roof construction is generally unacceptable in Scotland and not the preferred option elsewhere in the UK⁽¹⁾.

(1) See BRE Report BR 262 : 2002.

7.8 For roofs with a pitch of 10° to 15° and with a traditional (semi-permeable) sarking felt, where both the ceiling and insulation are horizontal, soffit ventilation products (including the over-fascia ventilator) with a minimum effective area of 7 000 mm² per metre run, if used in accordance with section 7.5, can provide adequate ventilation to insulated roof voids, as set out in BS 5250 : 2011, clause H.

7.9 Where soffit ventilation products are used in lean-to or mono-pitched roofs, high-level ventilation, in accordance with BS 5250 : 2011, clause H, must be provided.

7.10 Where a pitched roof abuts a wall, additional high-level ventilation must be arranged to provide an open area at least equal to a 5 mm slot running the full length of the abutment.

7.11 Soffit ventilation products meet NHBC requirements for protection against the ingress of birds, rodents or large insects.

7.12 The dimensions of the slots in the vented boards are such that the risk of blockage is limited. However, blockage by insects and debris would impair their performance as vents, and the slots should be examined occasionally and cleared if necessary.

8 Strength and stability

8.1 When installed in accordance with this Certificate and taking account of the site-specific circumstances, the system will withstand, without damage or permanent deflection, the wind loads likely to be encountered in the United Kingdom. In exposed locations, care should be taken to ensure that all profiles are adequately fixed.

8.2 The system has adequate resistance to the hard and soft body impacts likely to occur in practice.

8.3 PVC-U gutters, as specified in BS EN 607 : 2004, BS EN 1462 : 2004 and BS EN 12200-1 : 2016, may be screw-fixed directly to Ogee and Euroboards. Gutter bracket spacings must not exceed 1 metre; reduced spacings are recommended in the Scottish Highlands. Other lightweight gutters may also be screw-fixed provided the maximum bracket loading specified in BS EN 1462 : 2004 is not exceeded.

8.4 With the exception detailed in section 8.3, the fascia boards are not loadbearing and must not be used independently to support fixtures such as roof tiles, gutters or other roof structure components, or television aerials. Suitably fixed telephone wires and power cables may be run along the boards, but the main brackets for these services should be fixed through the fascia to structurally sound timber.

9 Performance in relation to fire



9.1 When tested in accordance with BS 476-7 : 1997, the 22 mm board achieved a Class 1 surface spread of flame rating, and the 9 mm board a Class 1Y rating.

9.2 On exposure to fire, PVC-U tends to char and may fall away. The spread of flame along its surface is limited. It is unlikely that the roof trim system will significantly affect the overall fire performance of any roof in which it is installed.

9.3 Where it is normal practice to carry the eaves box over, between dwellings, it is important that the box is fire-stopped at compartment walls.

10 Maintenance



10.1 The system can be cleaned by washing with water and mild detergent. Solvent-based, corrosive or abrasive cleaners should not be used. For the removal of more resistant stains, the Certificate holder's advice must be sought. The material can be cut and drilled using normal woodworking tools, if repairs are required.

10.2 As with all PVC products, paint can adversely affect the impact strength of the cellular PVC-UE sections, and the application of dark colours could lead to a risk of thermal distortion. Therefore painting is not recommended.

11 Durability



11.1 The system is as durable as conventional solid PVC-U and profiles, and will retain adequate impact resistance for a period in excess of 35 years.

11.2 The system will retain its decorative qualities for a period in excess of 35 years with only minor changes in surface appearance.

12 Reuse and recyclability

The PVC-U profiles and ancillary components of the system can be recycled.

13 General

- 13.1 Installation of the Eurocell PVC-U Roofline System must be carried out in accordance with the manufacturer's instructions and the requirements of this Certificate (see Figure 4).
- 13.2 Fascia, soffit and barge boards should be fixed to structurally sound timber at centres not exceeding 600 mm, using the screws and nails specified by the manufacturer.
- 13.3 Ogee and Euroboards may be used directly to support PVC-U and other lightweight gutters (see section 8.3).
- 13.4 Sarking felt should be checked to ensure that it is in good condition and extends onto the verge rafter and over a continuous tilting fillet and fascia into the gutter at the eaves. Damaged or worn felt should be replaced.
- 13.5 Ventilation products should be selected and installed so that the roof ventilation conforms to the relevant Building Regulations.
- 13.6 Normal precautions should be taken when working at roof level. The use of protective goggles when cutting and nailing is recommended.
- 13.7 The components of the system are easy to work using normal woodworking tools for cutting, drilling and shaping. Handsaws should have a fine-toothed blade. Hand-held and bench-mounted power tools with a carbide-tipped blade should be run at speeds similar to, or higher than, those normally used for timber.
- 13.8 When using power tools to cut or shape the product, it is advisable to use a coarse-particle dust mask and eye protection.

14 Procedure

- 14.1 Selected boards and accessories are assembled and cut to size.
- 14.2 Rafter feet are cut to a line.
- 14.3 Noggings, soffit bearers, battens, eaves fillets, brackets and other additional timber supports are fixed to a sound substrate.
- 14.4 Protective films should be removed prior to fixing.
- 14.5 The summary for the installation details of fascia, soffit and barge boards (see sections 14.6 to 14.17) should be read with reference to the typical installation diagrams shown in Figure 4.
- 14.6 All capping board profiles should be fixed either to a sound timber support or a 6 mm plywood backboard.

Fascias

- 14.7 Fascia boards are fixed to rafter feet at centres not exceeding 600 mm, using at least two fixings per rafter.
- 14.8 Butt joints between fascia boards should be made at the rafter end and covered with a butt joint trim, glued using a PVC solvent adhesive to the end of one board. Provision for expansion (minimum 10 mm gap) should be allowed between boards — all boards should be fixed to the rafter.
- 14.9 Corner trims are used to cover corner joints. The trims, with mitred ends, are glued using PVC solvent adhesive to the end of one board. Provision for expansion (minimum 5 mm gap) should be allowed between boards — all boards should be fixed to the rafter.

Soffits

- 14.10 Soffit board is used to construct the soffit.
- 14.11 The board is cut to size and fitted into the groove at the rear of the fascia or sat on the top of the capping board at the rafter end.
- 14.12 The boards are fixed to rafter feet, soffit bearers or other timber support at centres not exceeding 600 mm along their length or 200 mm along their width, using the specified nails.
- 14.13 Where required, soffit boards may be joined along their length or width using a soffit jointing strip.
- 14.14 Vented soffit board or soffit ventilator trims are used as required to comply with the national Building Regulations.

Barge boards

- 14.15 Barge boards are installed by fixing fascia boards to a gable ladder or noggings, using the procedures given in sections 14.16 and 14.17.

Figure 4 Typical installation details

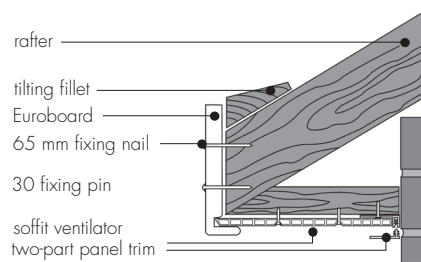
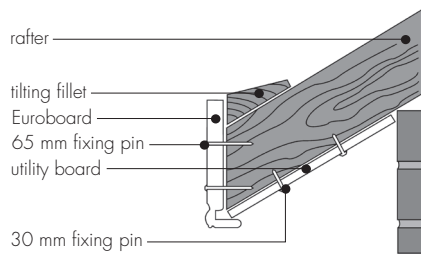
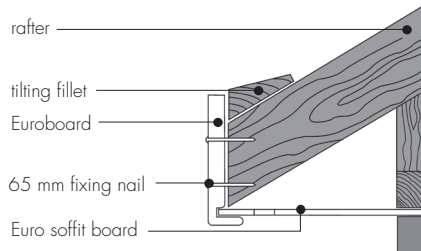
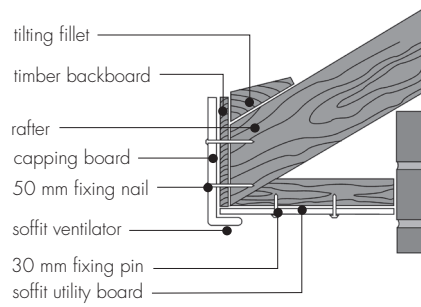
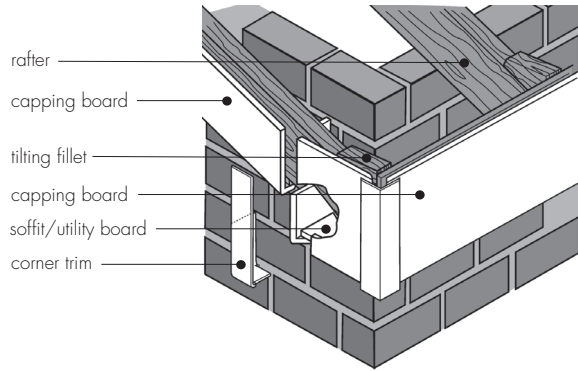
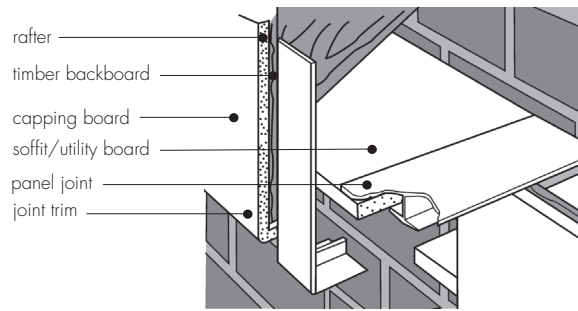

14.16 Barge boards meeting at a ridge should be mitred to the appropriate angle, allowing 5 mm for expansion between the ends of each board. To conceal the joint, a cover joint trim is fixed to the end of one board using a low-modulus neutral cure silicone. Further low-modulus neutral cure silicone sealant may be applied between the ends of the boards as an additional fixing.

14.17 Box ends are constructed from fascia board and trims to suit the roof pitch and overhang requirement. Any timber framework required in the construction of the box end must be preservative treated.

Technical Investigations

15 Tests

15.1 Tests were carried out on the PVC-UE profiles to determine:

- voidage
- thickness of layers
- density
- impact strength
- flexural strength and modulus of elasticity
- colour stability
- resistance to gutter loading
- impact strength after UV ageing
- suitability of adhesive.

15.2 Tests were carried out on the PVC-U trims to determine:

- heat reversion
- stress relief.

16 Investigations

16.1 The manufacturing process, including the methods adopted for quality control, were examined and details were obtained of the quality and composition of the materials used.

16.2 An assessment was made of the acceptability of soffit ventilators in meeting ventilation requirements.

16.3 An assessment was made of existing data relating to:

- surface spread of flame
- colour stability.

16.4 Assessment was made of the resistance of the products to wind suction.

16.5 The practicability of the installation was assessed.

Bibliography

BS 476-7 : 1997 *Fire tests on building materials and structures — Method of test to determine the classification of the surface spread of flame of products*

BS 5250 : 2011 + A1 : 2016 *Code of practice for control of condensation in buildings*

BS EN 607 : 2004 *Eaves gutters and fittings made of PVC-U — Definitions, requirements and testing*

BS EN 1462 : 2004 *Brackets for eaves gutters — Requirements and testing*

BS EN 1995-1-1 : 2004 + A2 : 2014 *Eurocode 5 : Design of timber structures — General — Common rules and rules for buildings*

NA to BS EN 1995-1-1 : 2004 + A1 : 2008 UK National Annex to *Eurocode 5 : Design of timber structures — General — Common rules and rules for buildings*

BS EN 12200-1 : 2016 *Plastics rainwater piping systems for above ground external use — Unplasticized poly (vinyl chloride) (PVC-U) — Specifications for pipes, fittings and the system*

BS EN 13245-2 : 2008 *Plastics — Unplasticized poly(vinyl chloride) (PVC-U) profiles for building applications — PVC-U profiles and PVC-UE profiles for internal and external wall and ceiling finishes*

BS EN ISO 9001 : 2015 *Quality management systems — Requirements*

BS EN ISO 14001 : 2015 *Environmental Management Systems — Requirements with guidance for use*

BRE Report (BR 262 : 2002) *Thermal insulation: avoiding risks*

17 Conditions

17.1 This Certificate:

- relates only to the product/system that is named and described on the front page
- is issued only to the company, firm, organisation or person named on the front page — no other company, firm, organisation or person may hold or claim that this Certificate has been issued to them
- is valid only within the UK
- has to be read, considered and used as a whole document — it may be misleading and will be incomplete to be selective
- is copyright of the BBA
- is subject to English Law.

17.2 Publications, documents, specifications, legislation, regulations, standards and the like referenced in this Certificate are those that were current and/or deemed relevant by the BBA at the date of issue or reissue of this Certificate.

17.3 This Certificate will remain valid for an unlimited period provided that the product/system and its manufacture and/or fabrication, including all related and relevant parts and processes thereof:

- are maintained at or above the levels which have been assessed and found to be satisfactory by the BBA
- continue to be checked as and when deemed appropriate by the BBA under arrangements that it will determine
- are reviewed by the BBA as and when it considers appropriate.

17.4 The BBA has used due skill, care and diligence in preparing this Certificate, but no warranty is provided.

17.5 In issuing this Certificate, the BBA is not responsible and is excluded from any liability to any company, firm, organisation or person, for any matters arising directly or indirectly from:

- the presence or absence of any patent, intellectual property or similar rights subsisting in the product/system or any other product/system
- the right of the Certificate holder to manufacture, supply, install, maintain or market the product/system
- actual installations of the product/system, including their nature, design, methods, performance, workmanship and maintenance
- any works and constructions in which the product/system is installed, including their nature, design, methods, performance, workmanship and maintenance
- any loss or damage, including personal injury, howsoever caused by the product/system, including its manufacture, supply, installation, use, maintenance and removal
- any claims by the manufacturer relating to CE marking.

17.6 Any information relating to the manufacture, supply, installation, use, maintenance and removal of this product/system which is contained or referred to in this Certificate is the minimum required to be met when the product/system is manufactured, supplied, installed, used, maintained and removed. It does not purport in any way to restate the requirements of the Health and Safety at Work etc. Act 1974, or of any other statutory, common law or other duty which may exist at the date of issue or reissue of this Certificate; nor is conformity with such information to be taken as satisfying the requirements of the 1974 Act or of any statutory, common law or other duty of care.